

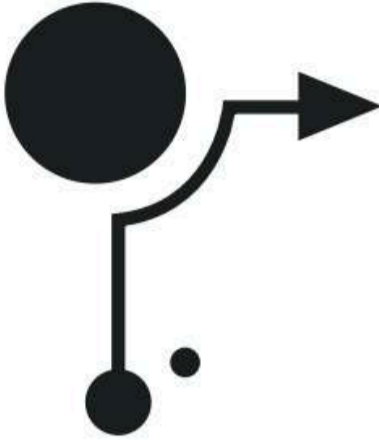







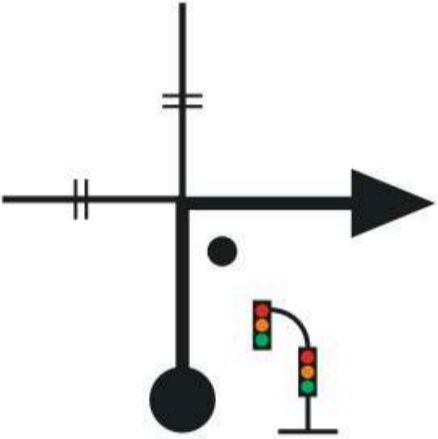

Σ.Ε.Χ. 0 ΛΟΥΤΡΑ ΛΑΓΚΑΔΑ		ΑΠΟΣΤΑΣΗ 8,25 χλμ.	ΣΚΕΛΟΣ 1	ΣΕΛ 1
Σ.Ε.Χ. 1 ΠΕΝΤΕ ΒΡΥΣΣΕΣ			ΤΜΗΜΑ 1	
ΕΙΔΙΚΗ ΔΙΑΔΡΟΜΗ		Μ.Ω.Τ. 41,35 χλμ.	ΙΔΑΝΙΚΟΣ ΧΡΟΝΟΣ	12'
ΟΛΙΚΑ ΧΛΜ	ΜΕΡΙΚΑ ΧΛΜ	ΚΑΤΕΥΘΥΝΣΗ	ΠΛΗΡΟΦΟΡΙΕΣ	ΥΠΟΛ ΧΛΜ
0,00	0,00	1 	 Σ.Ε.Χ. 0 ΕΞΟΔΟΣ PARKING ΛΟΥΤΡΩΝ ΛΑΓΚΑΔΑ	8,25
1,92	1,92	2 		6,33
2,05	0,13	3 		6,20
5,32	3,27	4 		2,93
8,25	2,93	5 	  Σ.Ε.Χ. 1 ΠΕΝΤΕ ΒΡΥΣΣΕΣ Ι ΑΦΕΤΗΡΙΑ Ε.Δ. ΣΕ 50μ 	0,00

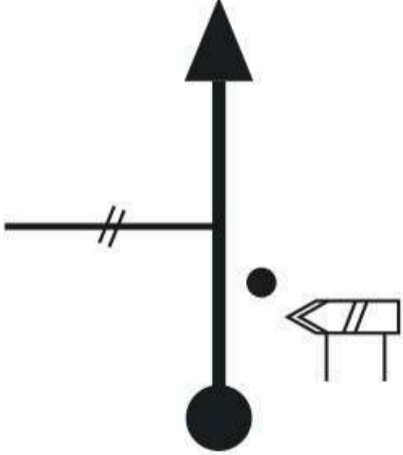
ΣΕΧ & ΑΦΕΤΗΡΙΑ Ε.Δ. ΠΕΝΤΕ ΒΡΥΣΕΣ

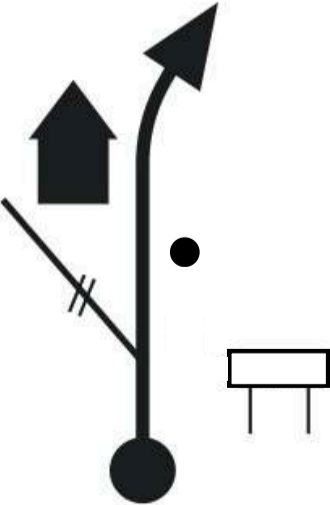

40°47'15"N 23°07'11"E

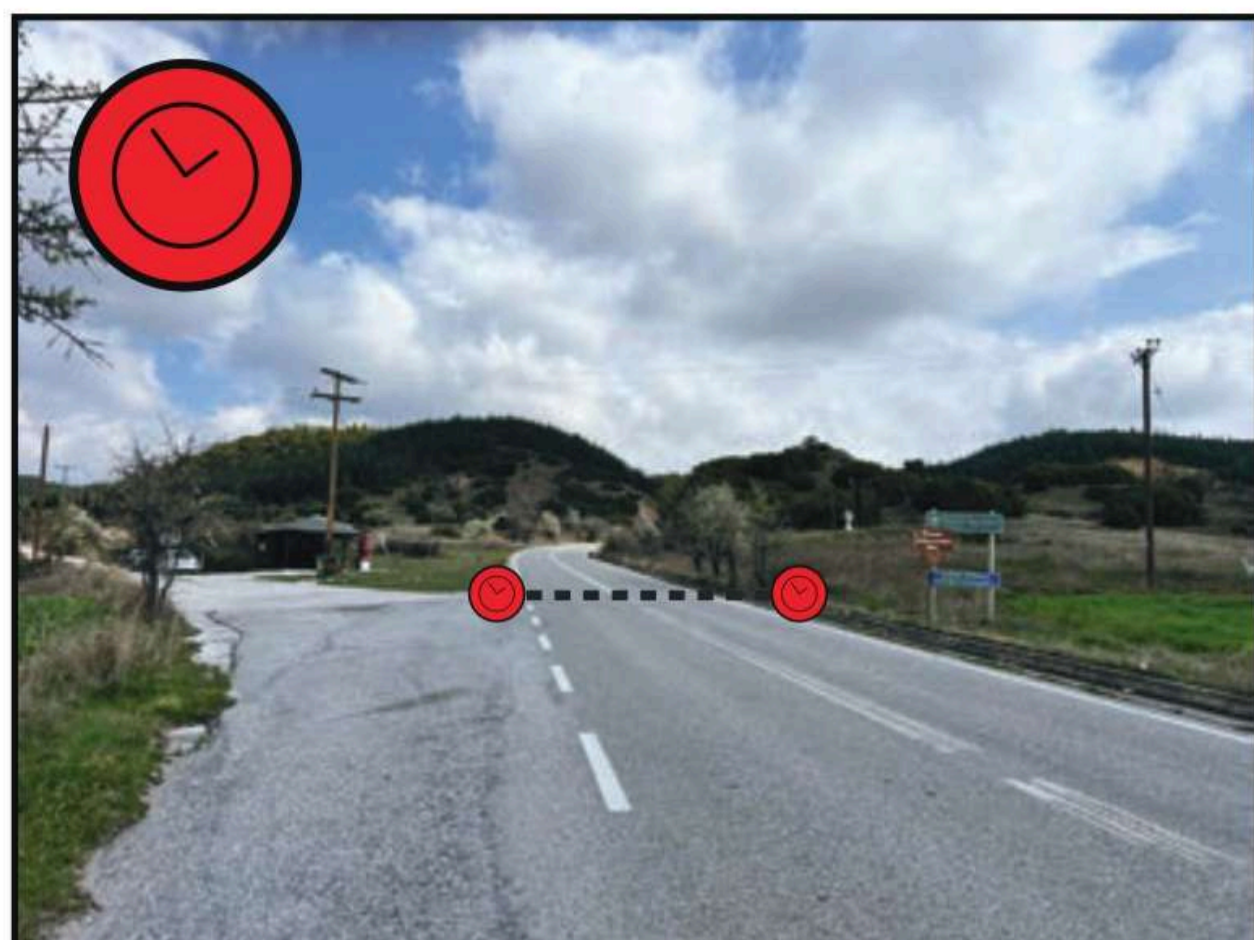

40°47'19"N 23°07'16.5"E



FLYING & STOP Ε.Δ. ΠΕΝΤΕ ΒΡΥΣΕΣ

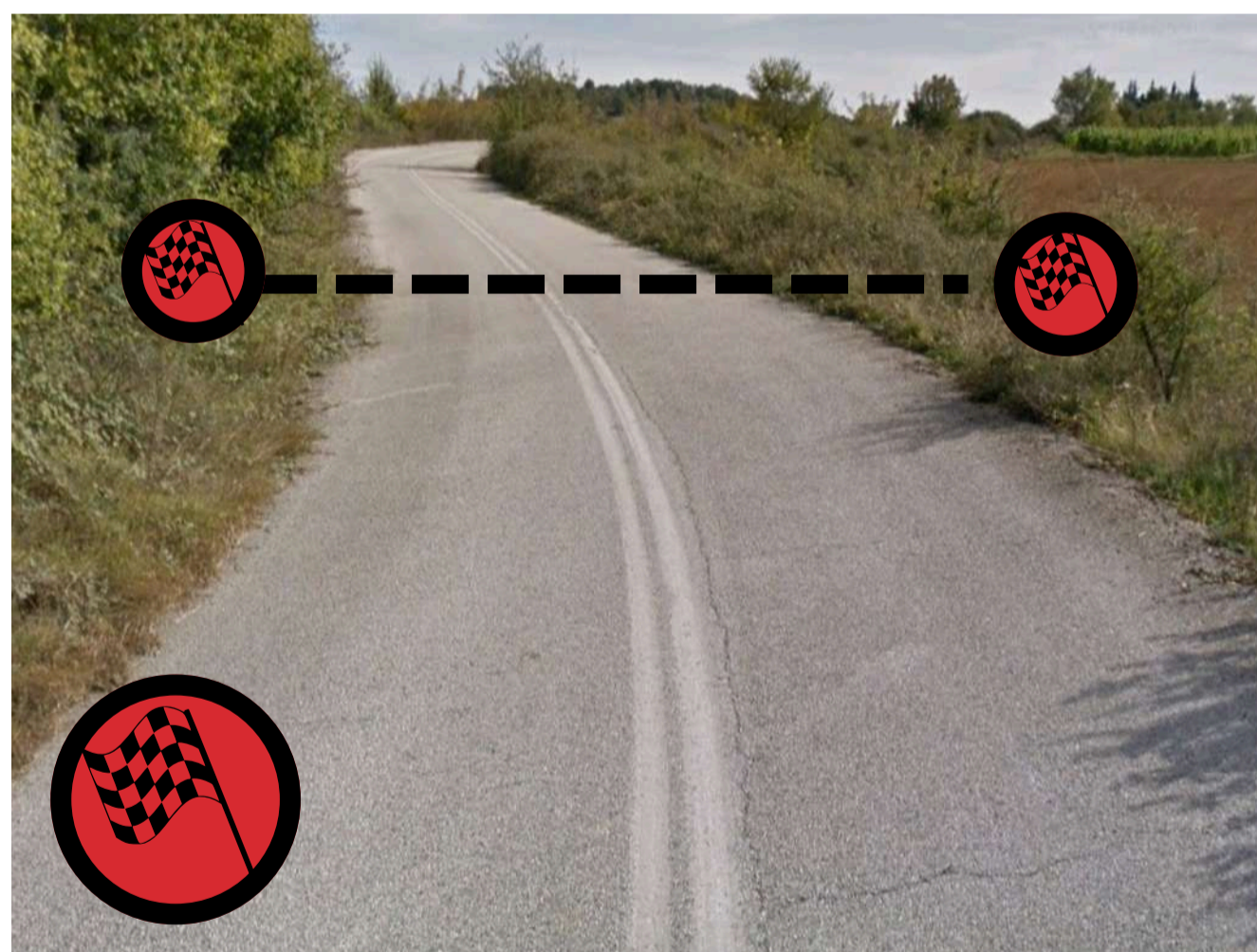



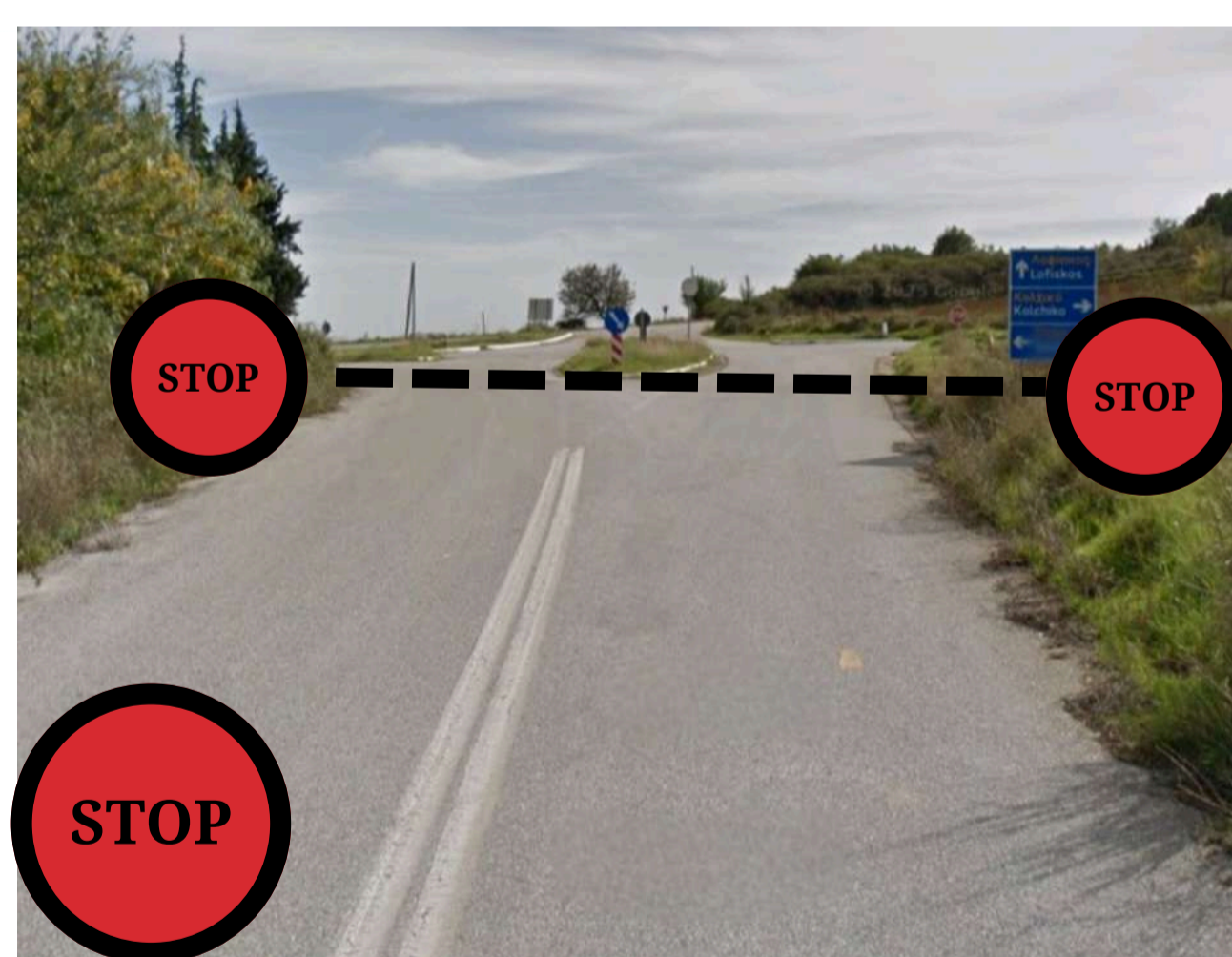











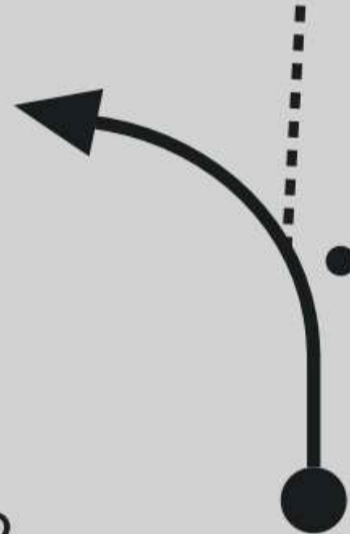

40°47'09.3"N 23°13'59.0"E



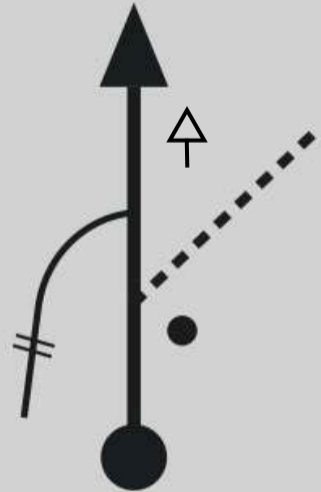







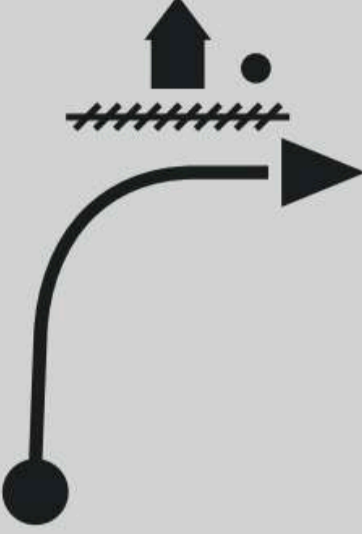

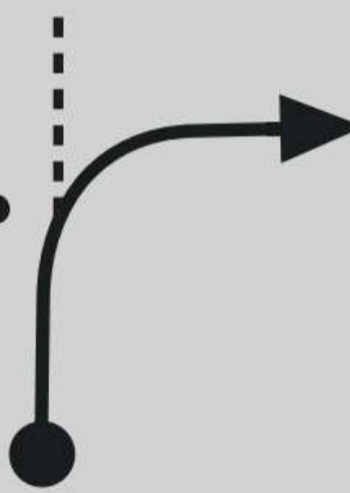

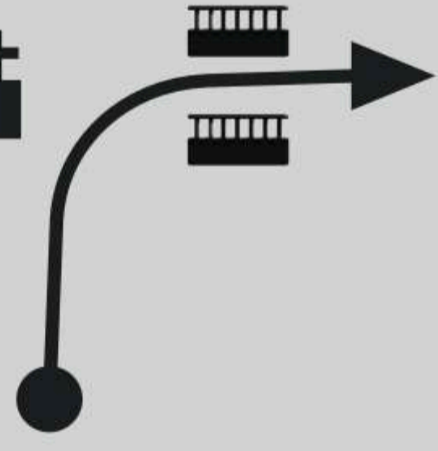





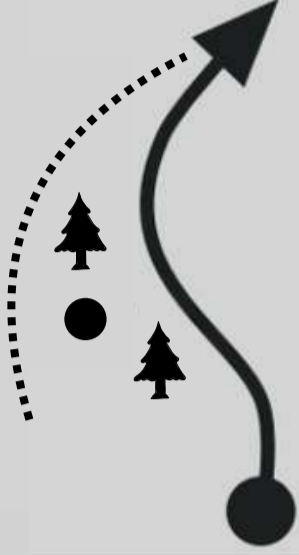

40°47'11"N 23°13'58"E



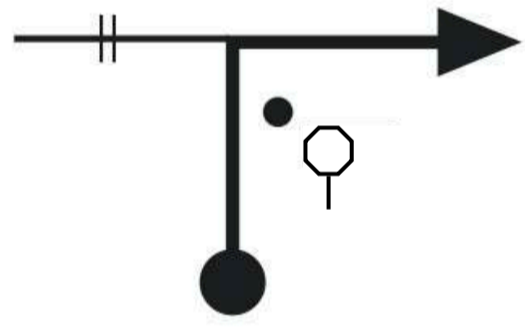

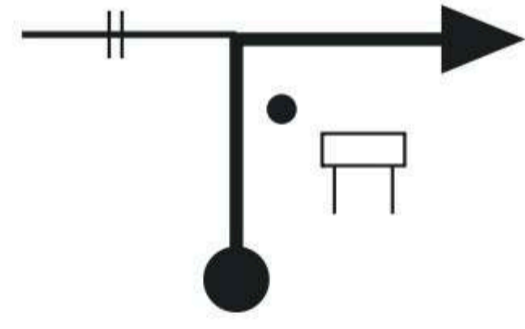





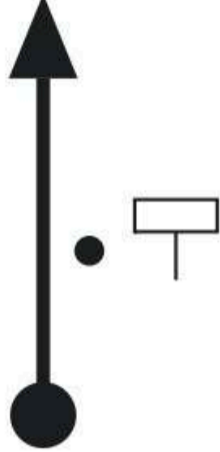

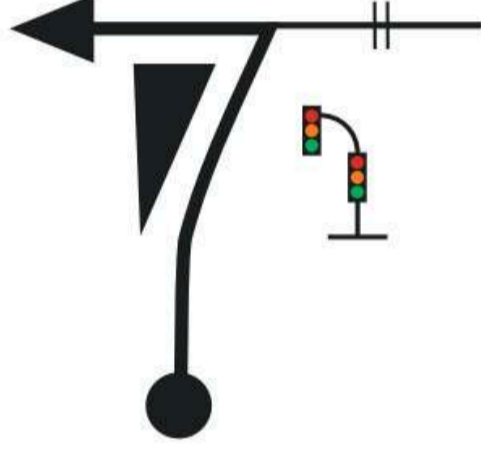

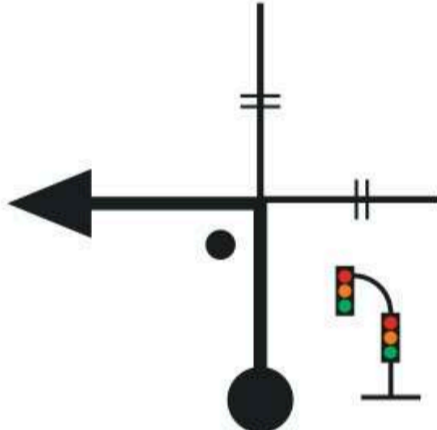
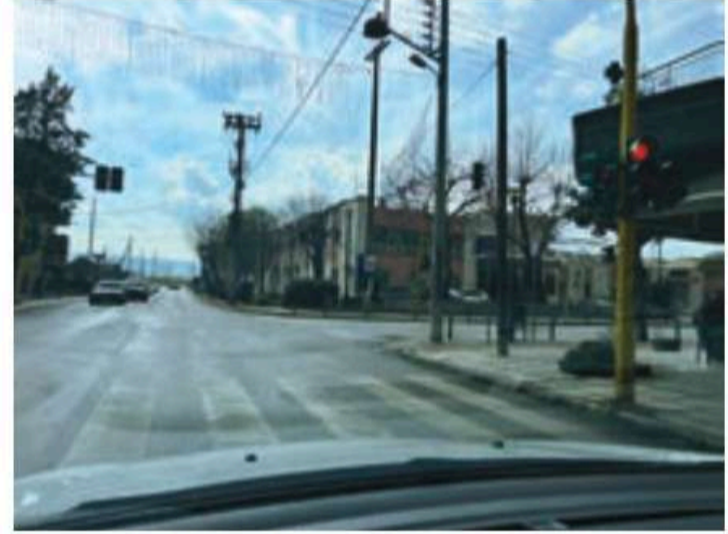
Σ.Ε.Χ. 1 ΠΕΝΤΕ ΒΡΥΣΣΕΣ		ΑΠΟΣΤΑΣΗ 32,22 χλμ.		ΣΚΕΛΟΣ 1	ΣΕΛ 2
Σ.Ε.Χ. 1Α REGROUPING IN A'				ΤΜΗΜΑ 1	
ΕΙΔΙΚΗ ΔΙΑΔΡΟΜΗ 1 - ΠΕΝΤΕ ΒΡΥΣΣΕΣ Ι		13,40 χλμ.	Μ.Ω.Τ. 48,33 χλμ.	ΙΔΑΝΙΚΟΣ ΧΡΟΝΟΣ	40'
ΟΛΙΚΑ ΧΛΜ	ΜΕΡΙΚΑ ΧΛΜ	ΚΑΤΕΥΘΥΝΣΗ	ΠΛΗΡΟΦΟΡΙΕΣ	ΥΠΟΛ ΧΛΜ	
0,00	0,00	1 	       ΑΦΕΤΗΡΙΑ Ε. Δ. 1 ΠΕΝΤΕ ΒΡΥΣΣΕΣ Ι 	32,22	
0,41	0,41	2 		31,81	
1,66	1,27	3 	 E2-1	30,56	
2,41	0,75	4 		29,81	
3,14	0,73	5 	 E4-1	29,08	





Σ.Ε.Χ. 1 ΠΕΝΤΕ ΒΡΥΣΣΕΣ		ΑΠΟΣΤΑΣΗ 32,22 χλμ.		ΣΚΕΛΟΣ 1	ΣΕΛ 3
Σ.Ε.Χ. 1Α REGROUPING IN A'				ΤΜΗΜΑ 1	
ΕΙΔΙΚΗ ΔΙΑΔΡΟΜΗ 1 - ΠΕΝΤΕ ΒΡΥΣΣΕΣ Ι		13,40 χλμ.	Μ.Ω.Τ. 48,33 χλμ.	ΙΔΑΝΙΚΟΣ ΧΡΟΝΟΣ	40'
ΟΛΙΚΑ ΧΛΜ	ΜΕΡΙΚΑ ΧΛΜ	ΚΑΤΕΥΘΥΝΣΗ	ΠΛΗΡΟΦΟΡΙΕΣ	ΥΠΟΛ ΧΛΜ	
3,56	0,42	6	 Κ.Π.Ε. ΒΕΡΤΙΣΚΟΥ		28,66
3,91	0,35	7	!! Ι. Μ. ΑΓΙΟΥ ΘΕΟΔΩΡΟΥ ΓΑΒΡΑ		28,31
4,80	0,89	8	 ΣΙΚΕΪΝ		27,42
4,88	0,08	9	 ΣΙΚΕΪΝ		27,34
6,52	1,64	10	 ΟΣΣΑ 5 ΒΕΡΤΙΣΚΟΣ 11		25,7

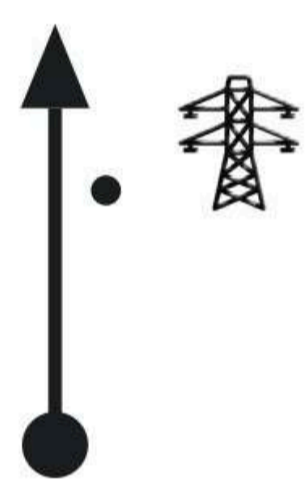







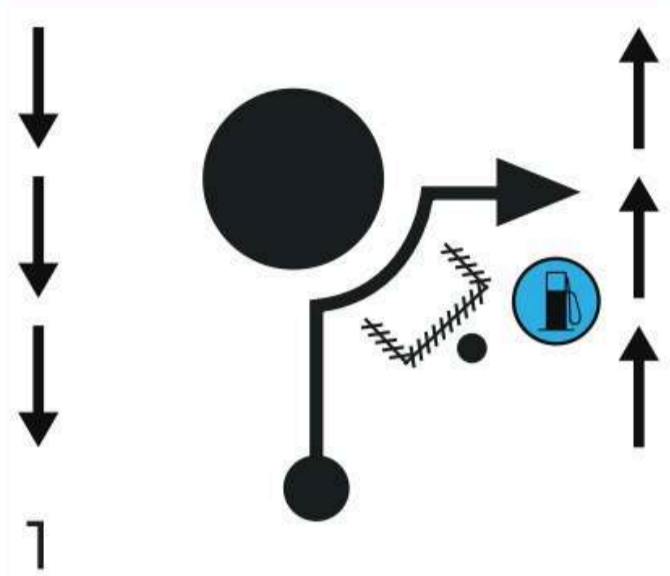

Σ.Ε.Χ. 1 ΠΕΝΤΕ ΒΡΥΣΕΣ		ΑΠΟΣΤΑΣΗ 32,22 χλμ.		ΣΚΕΛΟΣ 1	ΣΕΛ 4
Σ.Ε.Χ. 1Α REGROUPING IN A'				ΤΜΗΜΑ 1	
ΕΙΔΙΚΗ ΔΙΑΔΡΟΜΗ 1 - ΠΕΝΤΕ ΒΡΥΣΕΣ Ι		13,40 χλμ.	Μ.Ω.Τ. 48,33 χλμ.	ΙΔΑΝΙΚΟΣ ΧΡΟΝΟΣ	40'
ΟΛΙΚΑ ΧΛΜ	ΜΕΡΙΚΑ ΧΛΜ	ΚΑΤΕΥΘΥΝΣΗ	ΠΛΗΡΟΦΟΡΙΕΣ	ΥΠΟΛ ΧΛΜ	
8,12	1,52	11 			24,10
8,62	0,50	12 			23,60
9,70	1,08	13 			22,52
10,39	0,69	14 	 E12-1		21,83
11,41	1,02	15 	  ΠΥΛΩΝΕΣ Δ.Ε.Η.		20,81

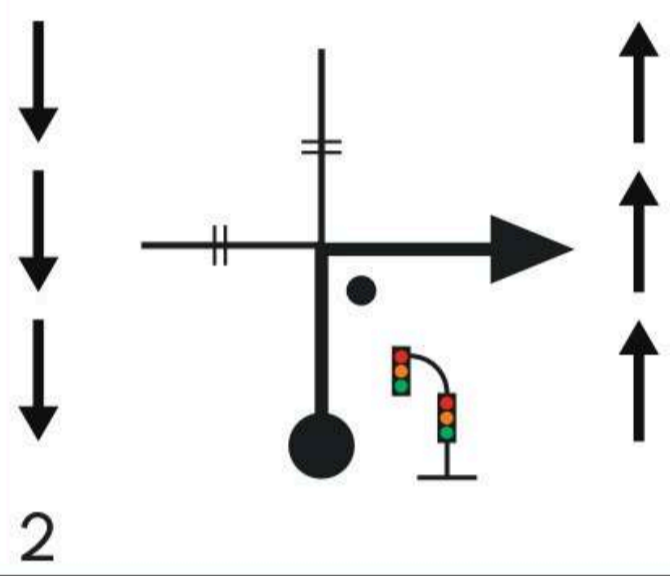
Σ.Ε.Χ. 1 ΠΕΝΤΕ ΒΡΥΣΣΕΣ		ΑΠΟΣΤΑΣΗ 32,22 χλμ.	ΣΚΕΛΟΣ 1	ΣΕΛ 5
Σ.Ε.Χ. 1Α REGROUPING IN A'			ΤΜΗΜΑ 1	
ΕΙΔΙΚΗ ΔΙΑΔΡΟΜΗ 1 - ΠΕΝΤΕ ΒΡΥΣΣΕΣ Ι		13,40 χλμ.	Μ.Ω.Τ. 48,33 χλμ.	ΙΔΑΝΙΚΟΣ ΧΡΟΝΟΣ 40'
ΟΛΙΚΑ ΧΛΜ	ΜΕΡΙΚΑ ΧΛΜ	ΚΑΤΕΥΘΥΝΣΗ	ΠΛΗΡΟΦΟΡΙΕΣ	ΥΠΟΛ ΧΛΜ
13,40	1,99	16 	 FLYING Ε.Δ. 1 ΠΕΝΤΕ ΒΡΥΣΣΕΣ	18,82
13,60	0,20	17 	  STOP Ε.Δ. 1 ΠΕΝΤΕ ΒΡΥΣΣΕΣ 	18,62
13,70	0,10	18 		18,52
24,10	10,40	19 	 500M	8,12
24,20	0,10	20 	 	8,02

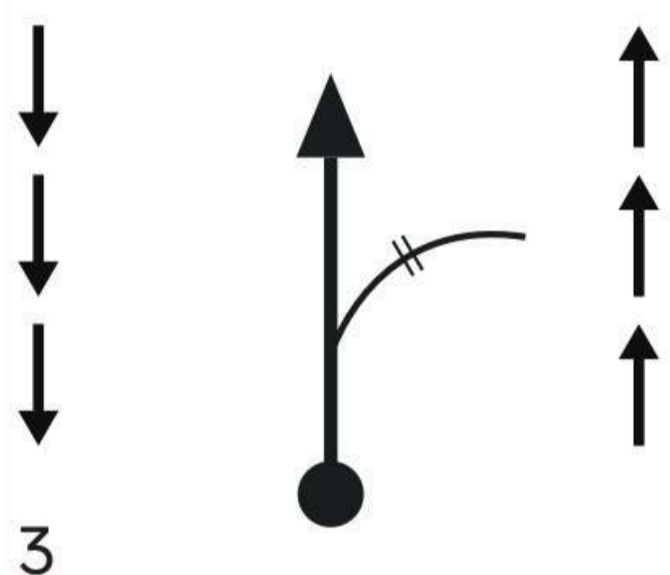
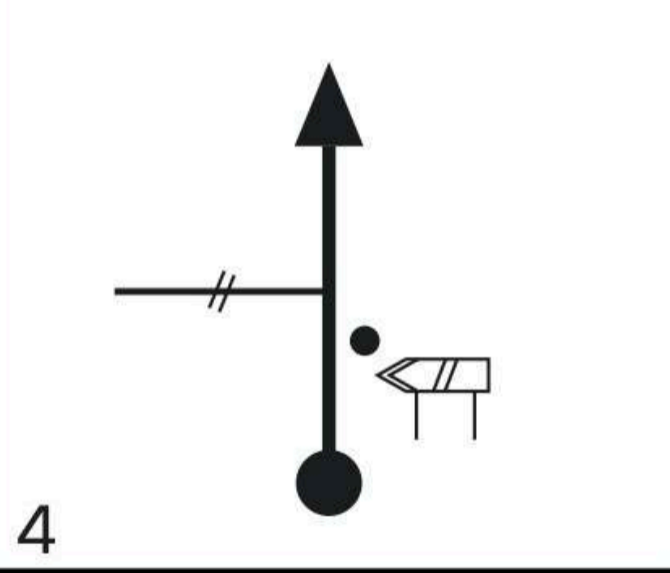
Σ.Ε.Χ. 1 ΠΕΝΤΕ ΒΡΥΣΣΕΣ		ΑΠΟΣΤΑΣΗ 32,22 χλμ.	ΣΚΕΛΟΣ 1	ΣΕΛ 6
Σ.Ε.Χ. 1Α REGROUPING IN A'			ΤΜΗΜΑ 1	
ΕΙΔΙΚΗ ΔΙΑΔΡΟΜΗ 1 - ΠΕΝΤΕ ΒΡΥΣΣΕΣ		13,40 χλμ.	Μ.Ω.Τ. 48,33 χλμ.	ΙΔΑΝΙΚΟΣ ΧΡΟΝΟΣ 40'
ΟΛΙΚΑ ΧΛΜ	ΜΕΡΙΚΑ ΧΛΜ	ΚΑΤΕΥΘΥΝΣΗ	ΠΛΗΡΟΦΟΡΙΕΣ	ΥΠΟΛ ΧΛΜ
29,16	4,96	21 	 ΚΑΛΩΣ ΗΛΘΑΤΕ ΣΤΟΝ ΛΑΓΚΑΔΑ	3,06
30,17	1,01	22 		2,05
30,30	0,13	23 		1,92
32,22	1,92	24 	  ΣΕΧ 1Α REGROUPING IN A' ΕΙΣΟΔΟΣ ΚΤΙΡΙΟΥ ΛΟΥΤΡΩΝ	0,00

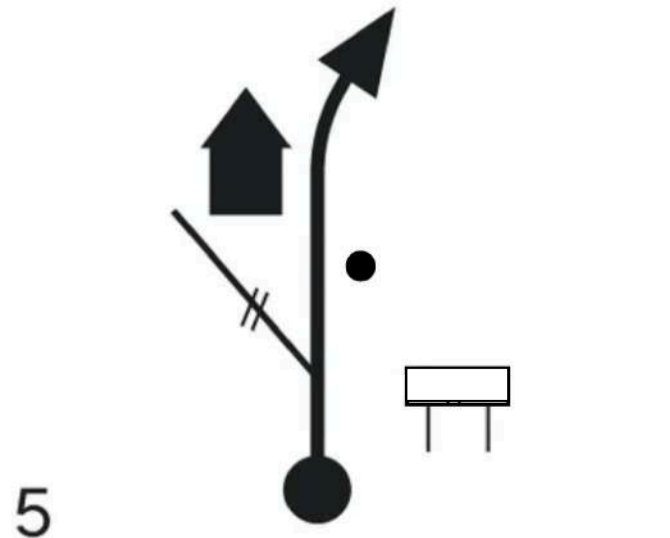
Σ.Ε.Χ. 1Α REGROUPING IN A'		ΑΠΟΣΤΑΣΗ	ΣΚΕΛΟΣ 1	ΣΕΛ 7
Σ.Ε.Χ. 1Β REGROUPING OUT A' - SERVICE PARK IN A'			ΤΜΗΜΑ 1	
		Μ.Ω.Τ.	ΙΔΑΝΙΚΟΣ ΧΡΟΝΟΣ	15'
ΟΛΙΚΑ ΧΛΜ	ΜΕΡΙΚΑ ΧΛΜ	ΚΑΤΕΥΘΥΝΣΗ	ΠΛΗΡΟΦΟΡΙΕΣ	ΥΠΟΛ ΧΛΜ
0,00	0,00	1 	 ΣΕΧ 1Α REGROUPING IN A' ΕΙΣΟΔΟΣ ΚΤΙΡΙΟΥ ΛΟΥΤΡΩΝ	0,00
0,00	0,00	2 	 ΣΕΧ 1Β REGROUPING OUT A' SERVICE PARK IN A'	0,00

Σ.Ε.Χ. 1B REGROUPING OUT A' - SERVICE PARK IN A'		ΑΠΟΣΤΑΣΗ	ΣΚΕΛΟΣ 1	ΣΕΛ 8
Σ.Ε.Χ. 1C SERVICE PARK OUT A'			ΤΜΗΜΑ 1	
		Μ.Ω.Τ.	ΙΔΑΝΙΚΟΣ ΧΡΟΝΟΣ	30'
ΟΛΙΚΑ ΧΛΜ	ΜΕΡΙΚΑ ΧΛΜ	ΚΑΤΕΥΘΥΝΣΗ	ΠΛΗΡΟΦΟΡΙΕΣ	ΥΠΟΛ ΧΛΜ
0,00	0,00	1 	 ΣΕΧ 1B REGROUPING OUT A' SERVICE PARK IN A' ΕΙΣΟΔΟΣ ΣΕ PARKING ΛΟΥΤΡΩΝ ΛΑΓΚΑΔΑ	0,00
0,00	0,00	2 	 ΣΕΧ 1C SERVICE PARK OUT B'	0,00

Σ.Ε.Χ. 1C SERVICE PARK OUT A'		ΑΠΟΣΤΑΣΗ 8,25 χλμ.	ΣΚΕΛΟΣ 1	ΣΕΛ 9
Σ.Ε.Χ. 2 ΠΕΝΤΕ ΒΡΥΣΣΕΣ II			ΤΜΗΜΑ 2	
ΕΙΔΙΚΗ ΔΙΑΔΡΟΜΗ		Μ.Ω.Τ. 33,00 χλμ.	ΙΔΑΝΙΚΟΣ ΧΡΟΝΟΣ	15'
ΟΛΙΚΑ ΧΛΜ	ΜΕΡΙΚΑ ΧΛΜ	ΚΑΤΕΥΘΥΝΣΗ	ΠΛΗΡΟΦΟΡΙΕΣ	ΥΠΟΛ ΧΛΜ
0,00	0,00		  Σ.Ε.Χ. 1C SERVICE PARK OUT A' ΕΠΙΤΡΕΠΕΤΑΙ Ο ΑΝΕΦΟΔΙΑΣΜΟΣ	8,25
1,92	1,92			6,33
2,05	0,13			6,20
5,32	3,27			2,93
8,25	2,93		  Σ.Ε.Χ. 2 ΠΕΝΤΕ ΒΡΥΣΣΕΣ II ΑΦΕΤΗΡΙΑ Ε.Δ. ΣΕ 50μ 	0,00

ΣΕΧ & ΑΦΕΤΗΡΙΑ Ε.Δ. ΠΕΝΤΕ ΒΡΥΣΕΣ

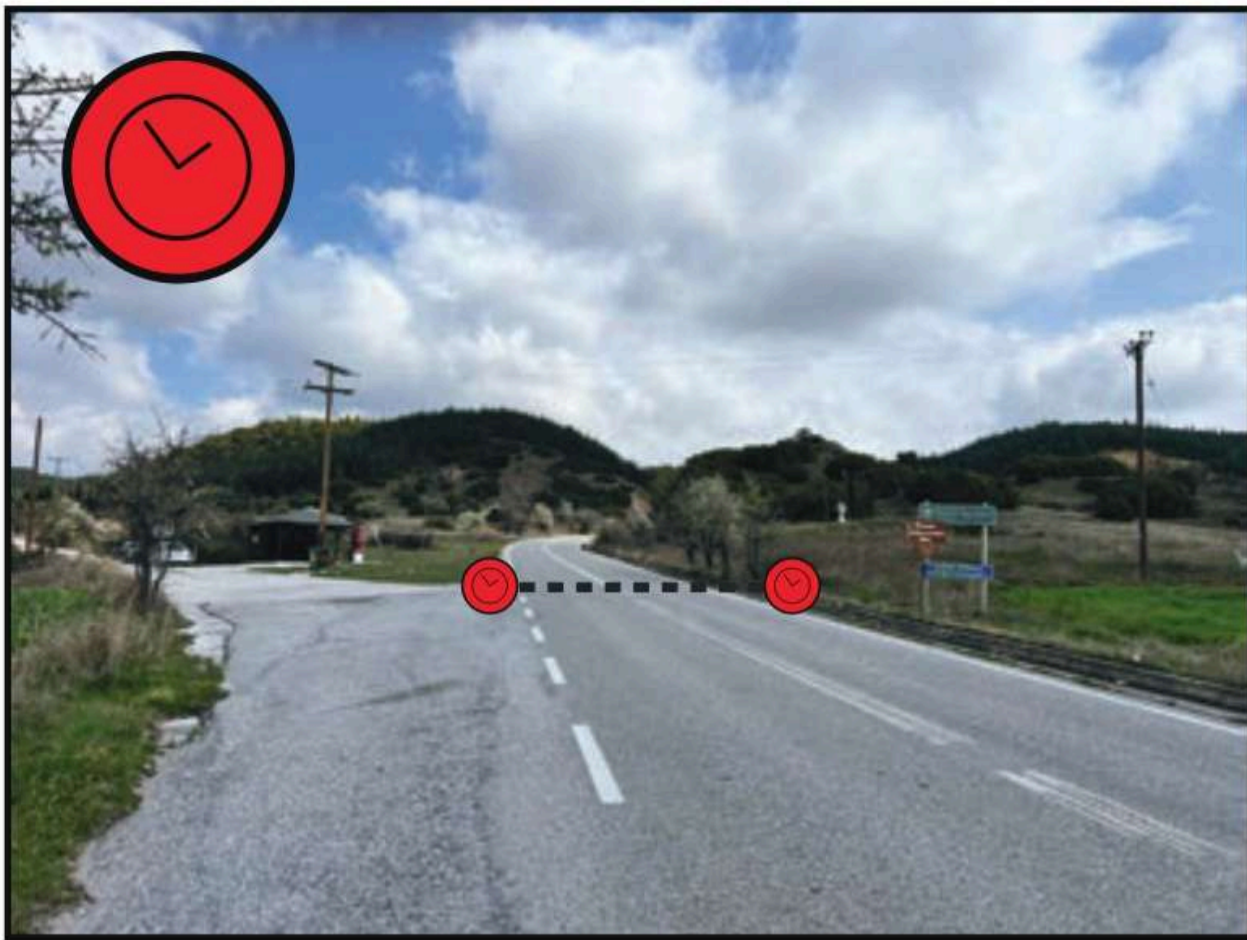

40°47'15"N 23°07'11"E



40°47'19"N 23°07'16.5"E



FLYING & STOP Ε.Δ. ΠΕΝΤΕ ΒΡΥΣΕΣ

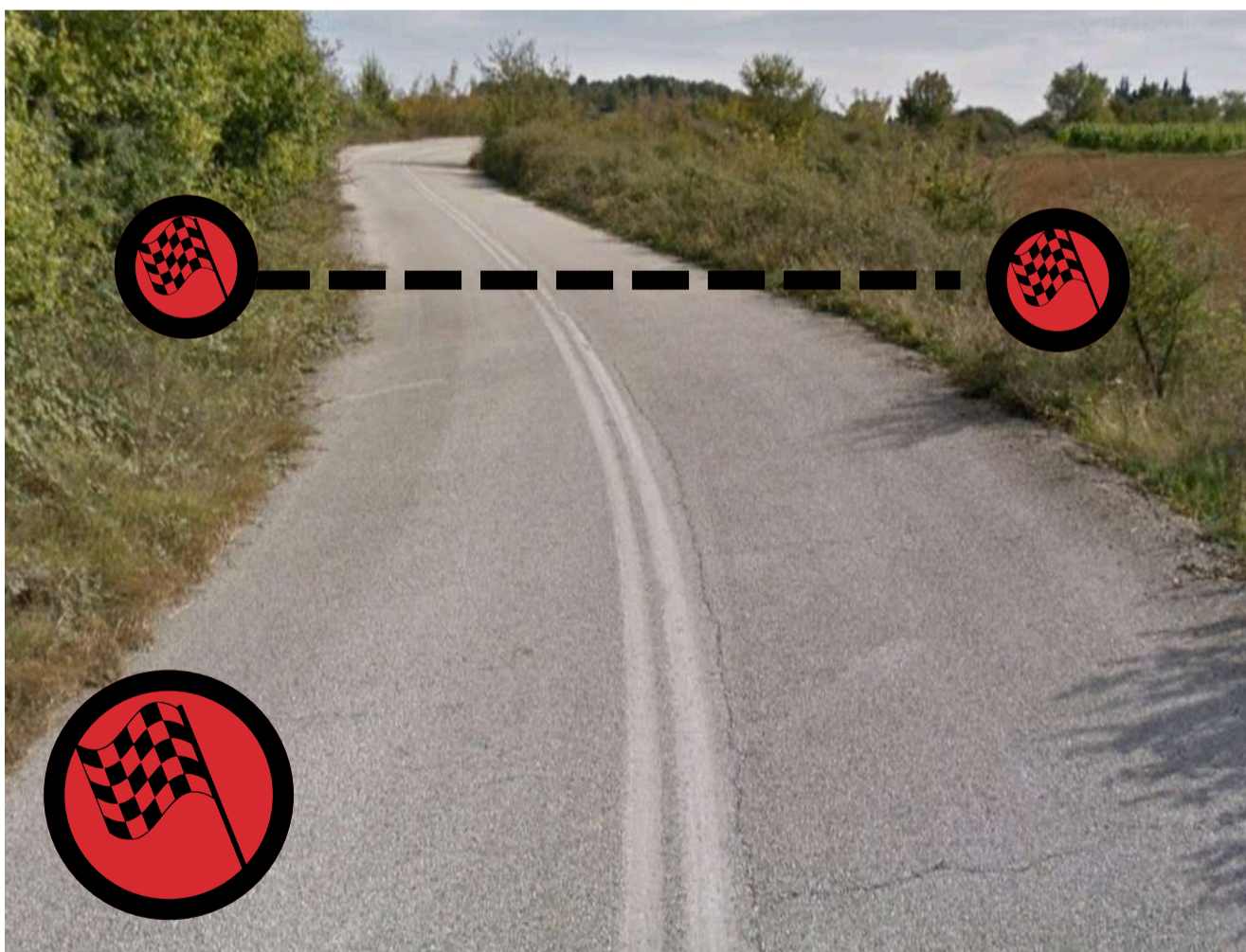



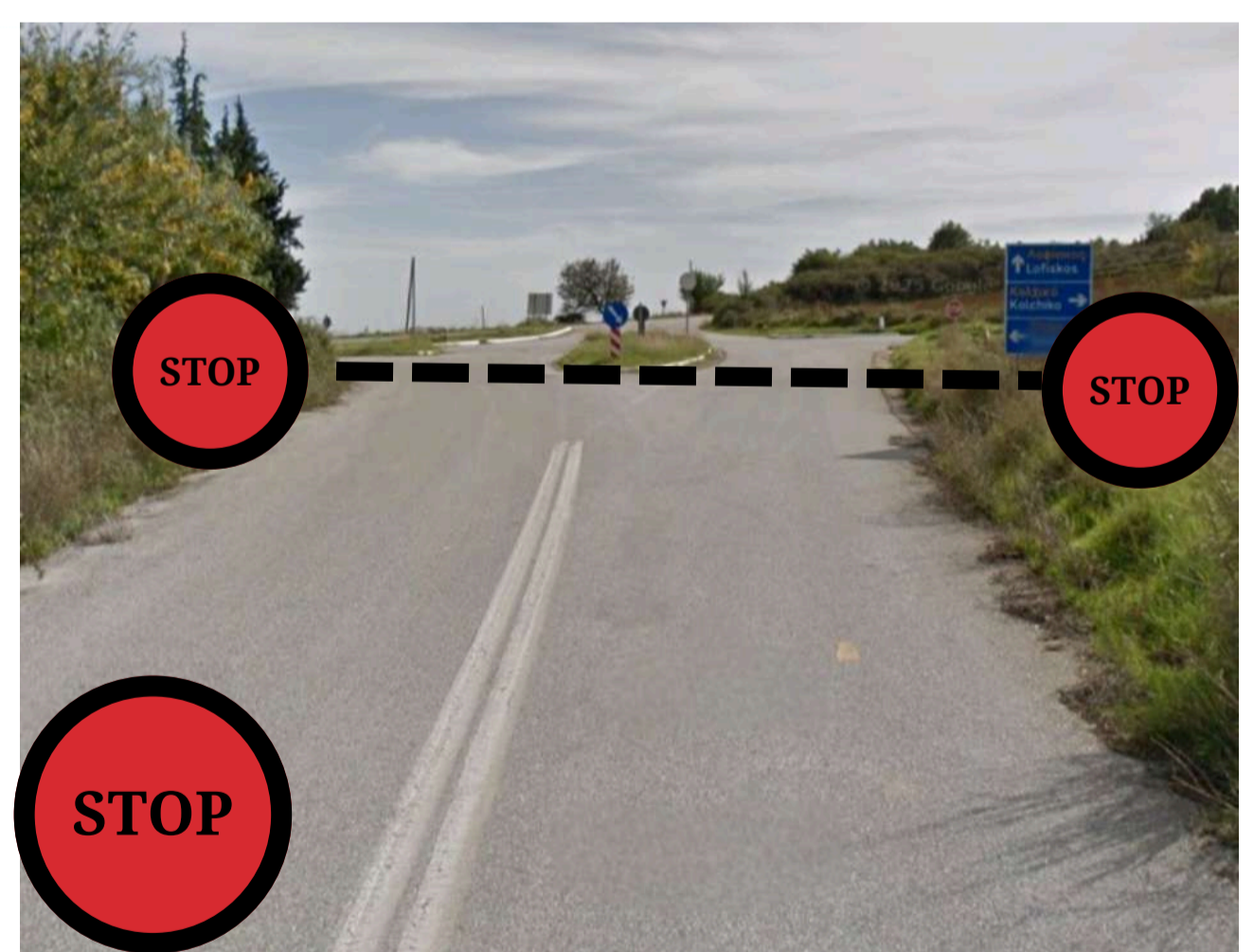













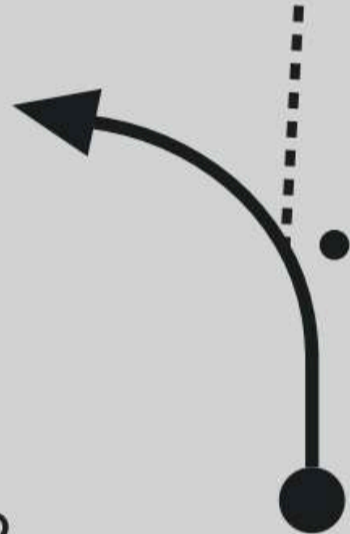



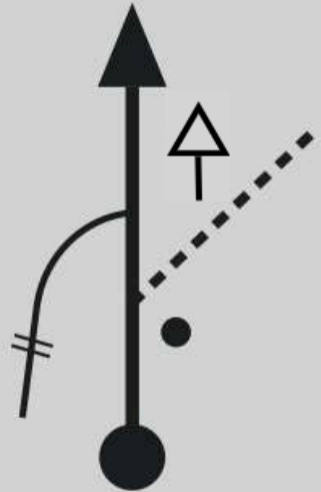

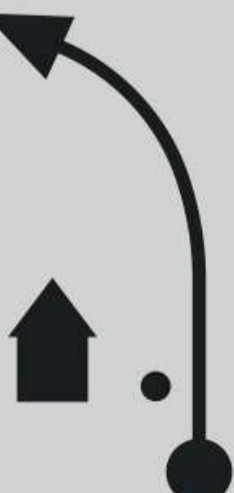

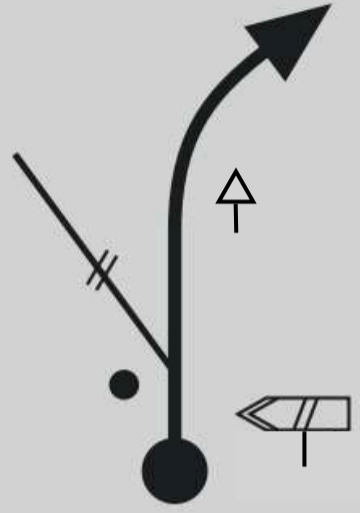

40°47'09.3"N 23°13'59.0"E

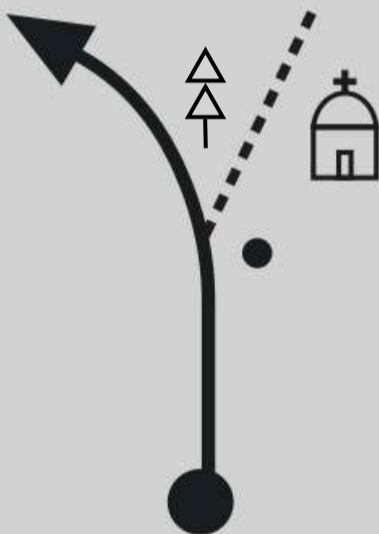

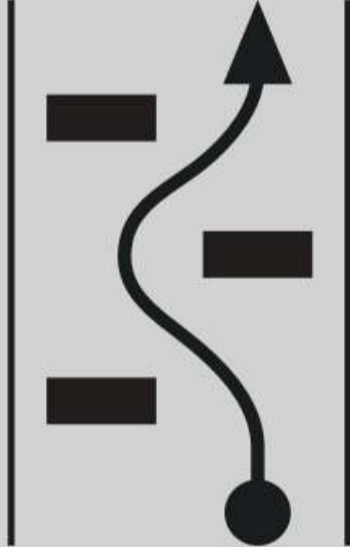

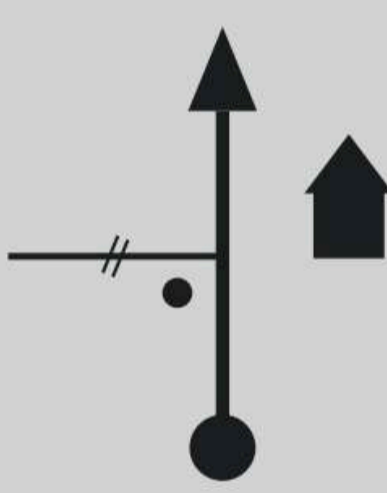

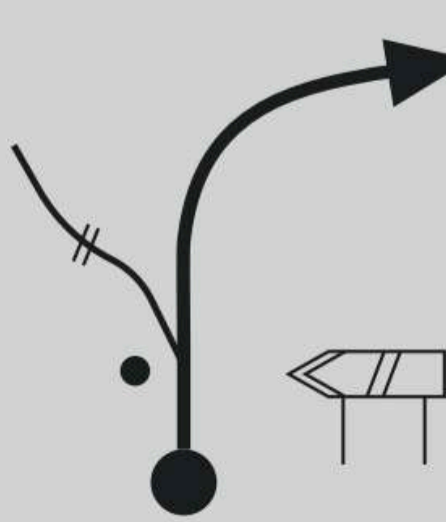

40°47'11"N 23°13'58"E

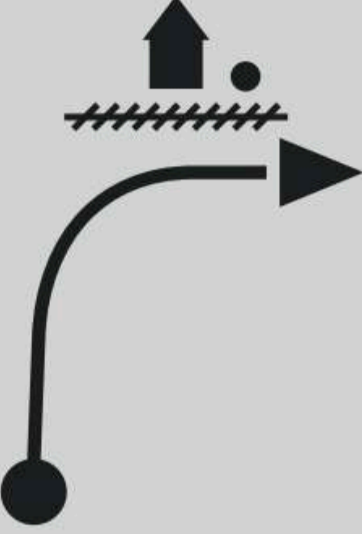

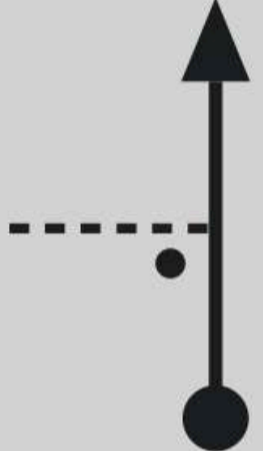
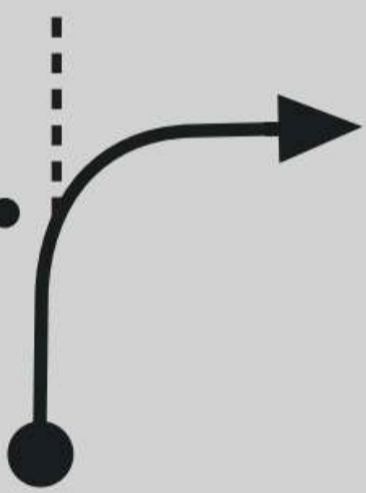
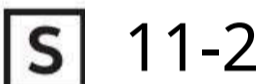
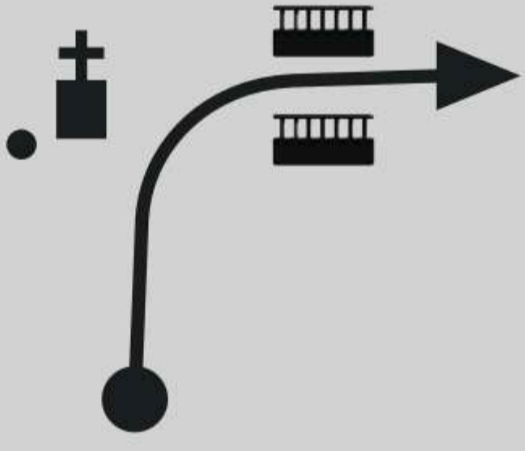







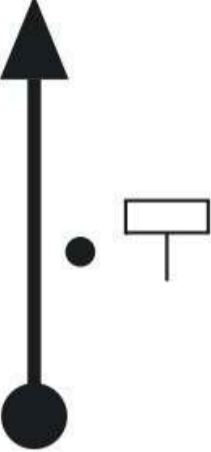

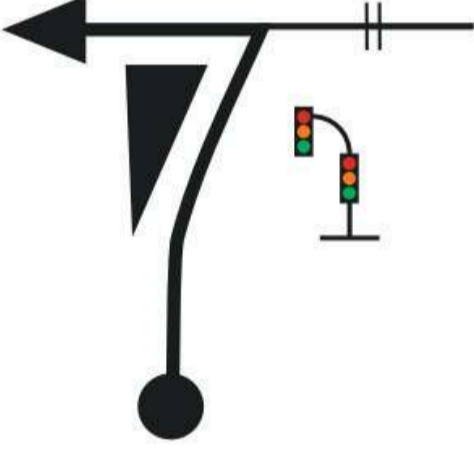

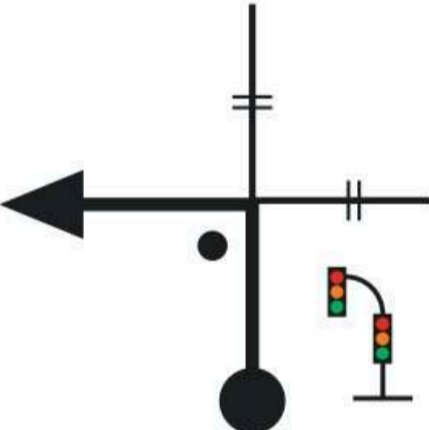
Σ.Ε.Χ. 2 ΠΕΝΤΕ ΒΡΥΣΣΕΣ II		ΑΠΟΣΤΑΣΗ 32,22 χλμ.		ΣΚΕΛΟΣ 1	ΣΕΛ 10
Σ.Ε.Χ. 2Α REGROUPING IN B'				ΤΜΗΜΑ 2	
ΕΙΔΙΚΗ ΔΙΑΔΡΟΜΗ 2 - ΠΕΝΤΕ ΒΡΥΣΣΕΣ II		13,40 χλμ.		Μ.Ω.Τ. 48,33 χλμ.	ΙΔΑΝΙΚΟΣ ΧΡΟΝΟΣ 40'
ΟΛΙΚΑ ΧΛΜ	ΜΕΡΙΚΑ ΧΛΜ	ΚΑΤΕΥΘΥΝΣΗ	ΠΛΗΡΟΦΟΡΙΕΣ	ΥΠΟΛ ΧΛΜ	
0,00	0,00	1 	       ΑΦΕΤΗΡΙΑ Ε. Δ. 2 ΠΕΝΤΕ ΒΡΥΣΣΕΣ II 	32,22	
0,41	0,41	2 		31,83	
1,66	1,27	3 		30,56	
2,41	0,75	4 		29,81	
3,14	0,73	5 		29,08	



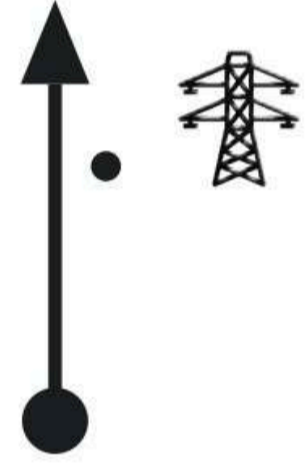

Σ.Ε.Χ. 2 ΠΕΝΤΕ ΒΡΥΣΣΕΣ II		ΑΠΟΣΤΑΣΗ 32,22 χλμ.		ΣΚΕΛΟΣ 1	ΣΕΛ 11
Σ.Ε.Χ. 2Α REGROUPING IN Β'				ΤΜΗΜΑ 2	
ΕΙΔΙΚΗ ΔΙΑΔΡΟΜΗ 2 - ΠΕΝΤΕ ΒΡΥΣΣΕΣ II		13,40 χλμ.		Μ.Ω.Τ. 48,33 χλμ.	ΙΔΑΝΙΚΟΣ ΧΡΟΝΟΣ 40'
ΟΛΙΚΑ ΧΛΜ	ΜΕΡΙΚΑ ΧΛΜ	ΚΑΤΕΥΘΥΝΣΗ	ΠΛΗΡΟΦΟΡΙΕΣ	ΥΠΟΛ ΧΛΜ	
3,56	0,42	6 	 E5-2 	28,66	
3,91	0,35	7 	!!  I. Μ. ΑΓΙΟΥ ΘΕΟΔΩΡΟΥ ΓΑΒΡΑ	28,31	
4,80	0,89	8 	 E7-2 ΣΙΚΕΪΝ	27,42	
4,88	0,08	9 		27,34	
6,52	1,64	10 	 E9-2 	25,7	

Σ.Ε.Χ. 2 ΠΕΝΤΕ ΒΡΥΣΣΕΣ ΙΙ		ΑΠΟΣΤΑΣΗ 32,22 χλμ.		ΣΚΕΛΟΣ 1	ΣΕΛ 12
Σ.Ε.Χ. 2Α REGROUPING IN Β'				ΤΜΗΜΑ 2	
ΕΙΔΙΚΗ ΔΙΑΔΡΟΜΗ 2 - ΠΕΝΤΕ ΒΡΥΣΣΕΣ ΙΙ		13,40 χλμ.		Μ.Ω.Τ. 48,33 χλμ.	ΙΔΑΝΙΚΟΣ ΧΡΟΝΟΣ 40'
ΟΛΙΚΑ ΧΛΜ	ΜΕΡΙΚΑ ΧΛΜ	ΚΑΤΕΥΘΥΝΣΗ	ΠΛΗΡΟΦΟΡΙΕΣ	ΥΠΟΛ ΧΛΜ	
8,12	1,52	11 		24,10	
8,62	0,50	12 		23,60	
9,70	1,08	13 		22,52	
10,39	0,69	14 	 E12-2	21,83	
11,41	1,02	15 	  ΠΥΛΩΝΕΣ Δ.Ε.Η.	20,81	

Σ.Ε.Χ. 2 ΠΕΝΤΕ ΒΡΥΣΣΕΣ II		ΑΠΟΣΤΑΣΗ 32,22 χλμ.	ΣΚΕΛΟΣ 1	ΣΕΛ 13
Σ.Ε.Χ. 2Α REGROUPING IN B'			ΤΜΗΜΑ 2	
ΕΙΔΙΚΗ ΔΙΑΔΡΟΜΗ 2 - ΠΕΝΤΕ ΒΡΥΣΣΕΣ II		13,40 χλμ.	Μ.Ω.Τ. 48,33 χλμ.	ΙΔΑΝΙΚΟΣ ΧΡΟΝΟΣ 40'
ΟΛΙΚΑ ΧΛΜ	ΜΕΡΙΚΑ ΧΛΜ	ΚΑΤΕΥΘΥΝΣΗ	ΠΛΗΡΟΦΟΡΙΕΣ	ΥΠΟΛ ΧΛΜ
13,40	1,99	16	 FLYING Ε.Δ. 2 ΠΕΝΤΕ ΒΡΥΣΣΕΣ	18,82
13,60	0,20	17	 STOP Ε.Δ. 2 ΠΕΝΤΕ ΒΡΥΣΣΕΣ	18,62
13,70	0,10	18		18,52
24,10	10,40	19		8,12
24,20	0,10	20		8,02

Σ.Ε.Χ. 2 ΠΕΝΤΕ ΒΡΥΣΣΕΣ II		ΑΠΟΣΤΑΣΗ 32,22 χλμ.	ΣΚΕΛΟΣ 1	ΣΕΛ 14
Σ.Ε.Χ. 2Α REGROUPING IN B'			ΤΜΗΜΑ 2	
ΕΙΔΙΚΗ ΔΙΑΔΡΟΜΗ 2 - ΠΕΝΤΕ ΒΡΥΣΣΕΣ II		13,40 χλμ.	Μ.Ω.Τ. 48,33 χλμ.	ΙΔΑΝΙΚΟΣ ΧΡΟΝΟΣ 40'
ΟΛΙΚΑ ΧΛΜ	ΜΕΡΙΚΑ ΧΛΜ	ΚΑΤΕΥΘΥΝΣΗ	ΠΛΗΡΟΦΟΡΙΕΣ	ΥΠΟΛ ΧΛΜ
29,16	4,96	21 	 ΚΑΛΩΣ ΗΛΘΑΤΕ ΣΤΟΝ ΛΑΓΚΑΔΑ	3,06
30,17	1,01	22 		2,05
30,30	0,13	23 		1,92
32,22	1,92	24 	  ΣΕΧ 2Α REGROUPING IN B' ΕΙΣΟΔΟΣ ΚΤΙΡΙΟΥ ΛΟΥΤΡΩΝ	0,00

Σ.Ε.Χ. 2Α REGROUPING IN B'		ΑΠΟΣΤΑΣΗ	ΣΚΕΛΟΣ 1	ΣΕΛ 15
Σ.Ε.Χ. 2Β REGROUPING OUT B' - SERVICE PARK IN B'			ΤΜΗΜΑ 2	
		Μ.Ω.Τ.	ΙΔΑΝΙΚΟΣ ΧΡΟΝΟΣ	15'
ΟΛΙΚΑ ΧΛΜ	ΜΕΡΙΚΑ ΧΛΜ	ΚΑΤΕΥΘΥΝΣΗ	ΠΛΗΡΟΦΟΡΙΕΣ	ΥΠΟΛ ΧΛΜ
0,00	0,00	1 	 ΣΕΧ 2Α REGROUPING IN B' ΕΙΣΟΔΟΣ ΚΤΙΡΙΟΥ ΛΟΥΤΡΩΝ	0,00
0,00	0,00	2 	 ΣΕΧ 2Β REGROUPING OUT B' SERVICE PARK IN B'	0,00

Σ.Ε.Χ. 2B REGROUPING OUT B' - SERVICE PARK IN B'		ΑΠΟΣΤΑΣΗ	ΣΚΕΛΟΣ 1	ΣΕΛ 16
Σ.Ε.Χ. 2C SERVICE PARK OUT B'			ΤΜΗΜΑ 2	
		Μ.Ω.Τ.	ΙΔΑΝΙΚΟΣ ΧΡΟΝΟΣ	30'
ΟΛΙΚΑ ΧΛΜ	ΜΕΡΙΚΑ ΧΛΜ	ΚΑΤΕΥΘΥΝΣΗ	ΠΛΗΡΟΦΟΡΙΕΣ	ΥΠΟΛ ΧΛΜ
0,00	0,00	1 	 ΣΕΧ 2B REGROUPING OUT B' SERVICE PARK IN B' ΕΙΣΟΔΟΣ ΣΕ PARKING ΛΟΥΤΡΩΝ ΛΑΓΚΑΔΑ	0,00
0,00	0,00	2 	 ΣΕΧ 2C SERVICE PARK OUT B'	0,00

Σ.Ε.Χ. 3 ΛΟΥΤΡΑ ΛΑΓΚΑΔΑ		ΑΠΟΣΤΑΣΗ 8,25 χλμ.	ΣΚΕΛΟΣ 1	ΣΕΛ 17
Σ.Ε.Χ. 3 ΠΕΝΤΕ ΒΡΥΣΣΕΣ ΙΙΙ			ΤΜΗΜΑ 3	
ΕΙΔΙΚΗ ΔΙΑΔΡΟΜΗ		Μ.Ω.Τ. 33,00 χλμ.	ΙΔΑΝΙΚΟΣ ΧΡΟΝΟΣ	15'
ΟΛΙΚΑ ΧΛΜ	ΜΕΡΙΚΑ ΧΛΜ	ΚΑΤΕΥΘΥΝΣΗ	ΠΛΗΡΟΦΟΡΙΕΣ	ΥΠΟΛ ΧΛΜ
0,00	0,00		 Refueling Zone 2 Σ.Ε.Χ. 2C SERVICE PARK OUT B' ΛΟΥΤΡΑ ΛΑΓΚΑΔΑ ΕΠΙΤΡΕΠΕΤΑΙ Ο ΑΝΕΦΟΔΙΑΣΜΟΣ	8,25
1,92	1,92			6,33
2,05	0,13			6,20
5,32	3,27			2,93
8,25	2,93		 ΠΕΝΤΕ ΒΡΥΣΣΕΣ Σ.Ε.Χ. 3 ΠΕΝΤΕ ΒΡΥΣΣΕΣ ΙΙΙ ΑΦΕΤΗΡΙΑ Ε.Δ. ΣΕ 50μ 	0,00

ΣΕΧ & ΑΦΕΤΗΡΙΑ Ε.Δ. ΠΕΝΤΕ ΒΡΥΣΕΣ

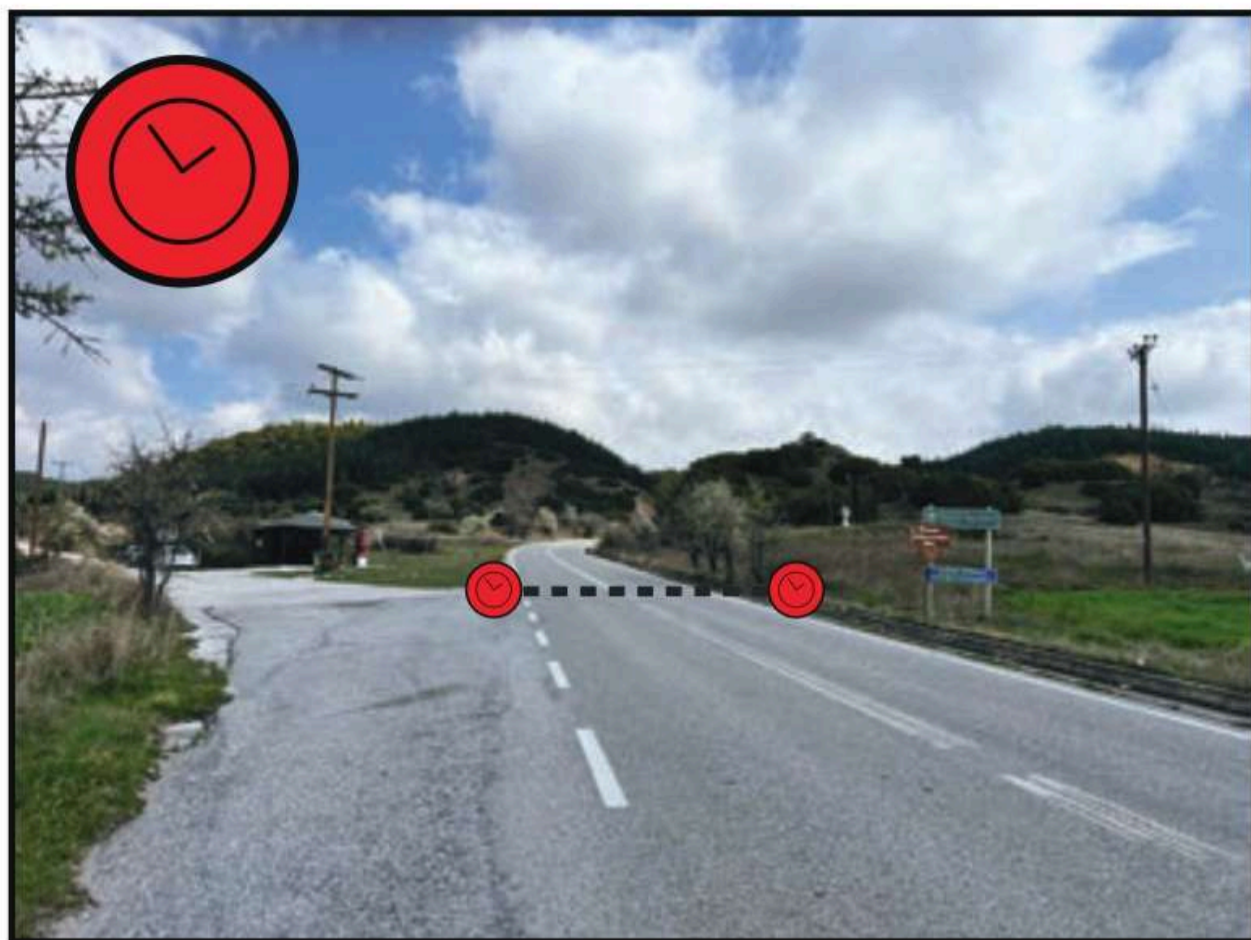

40°47'15"N 23°07'11"E



40°47'19"N 23°07'16.5"E



FLYING & STOP Ε.Δ. ΠΕΝΤΕ ΒΡΥΣΕΣ

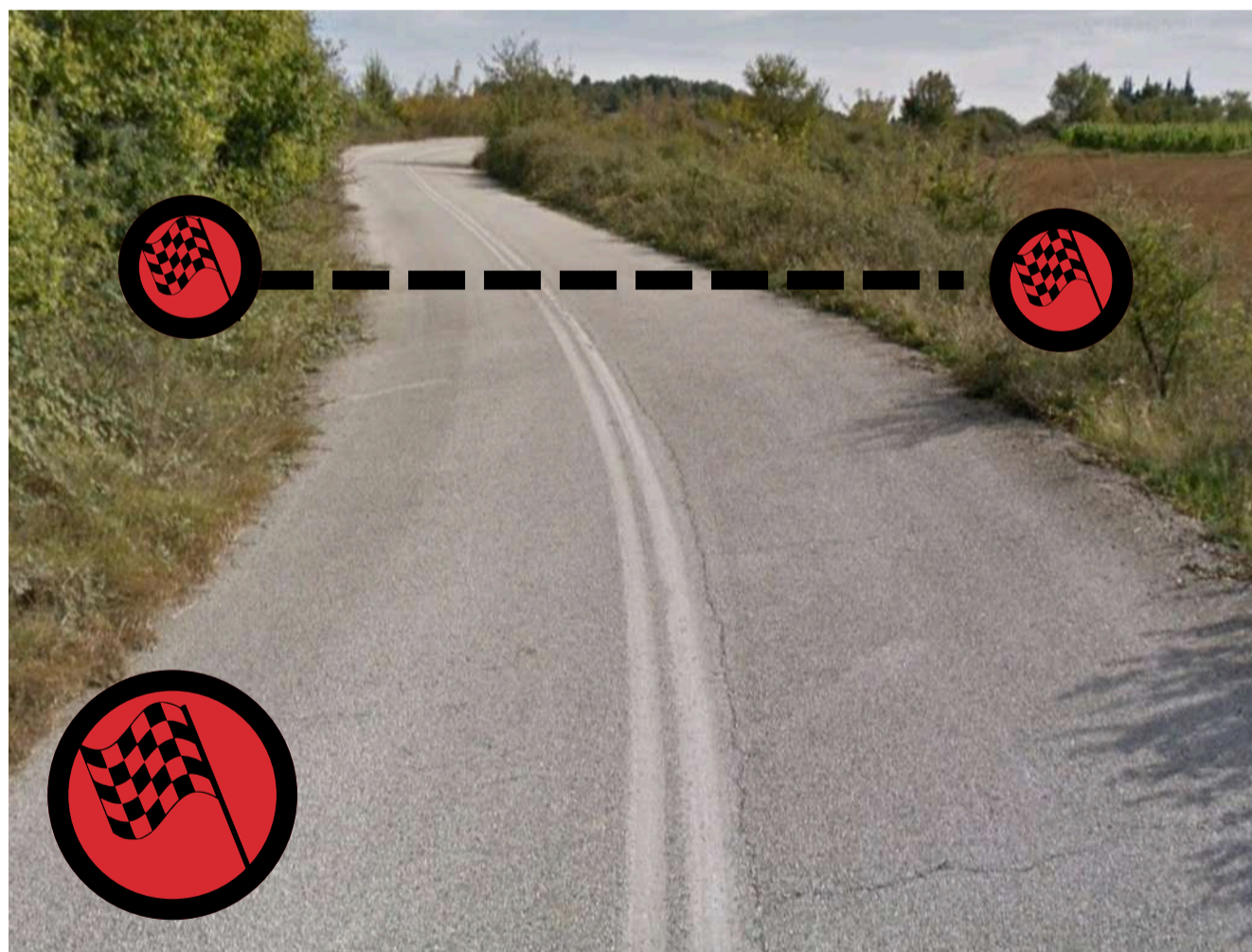



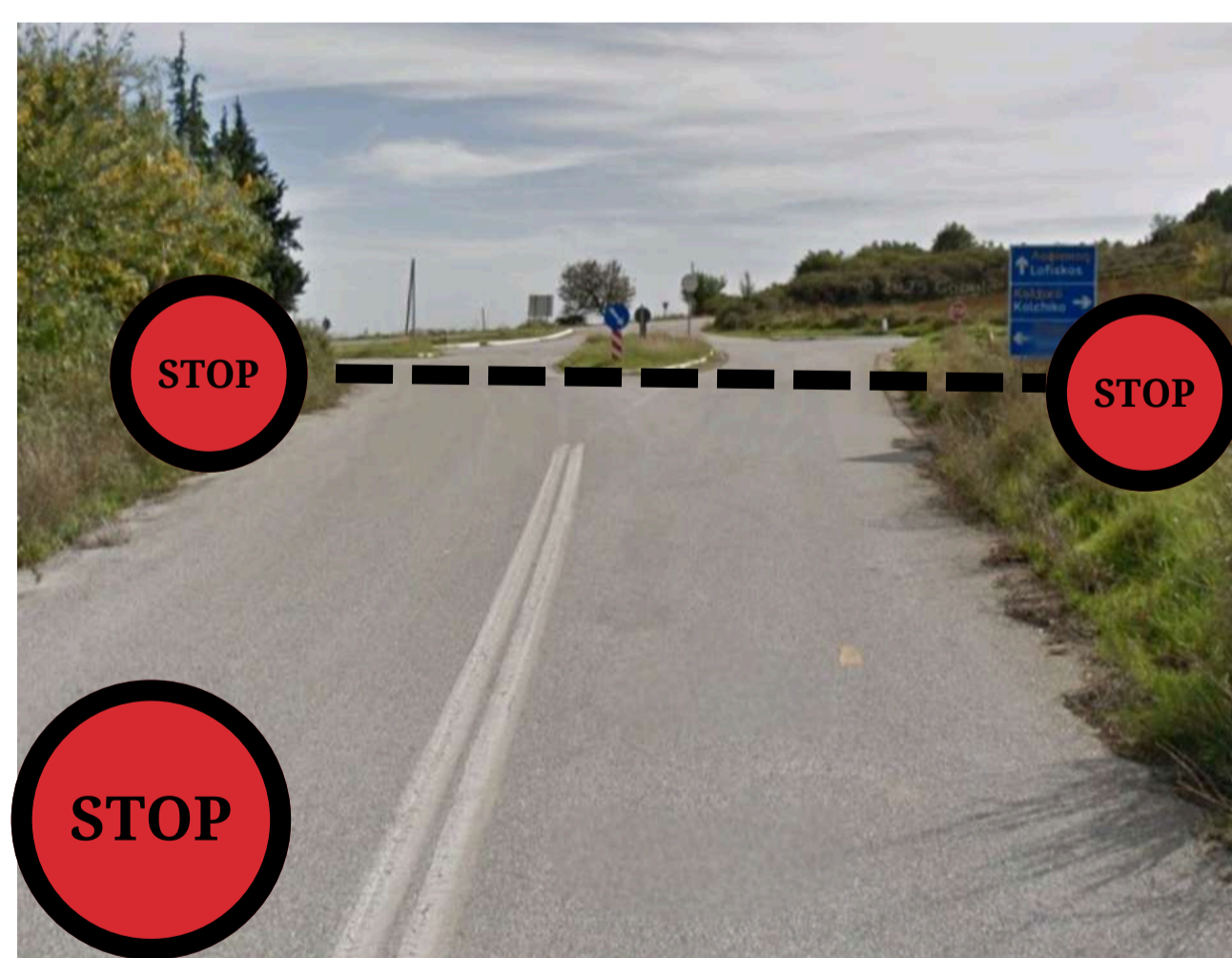











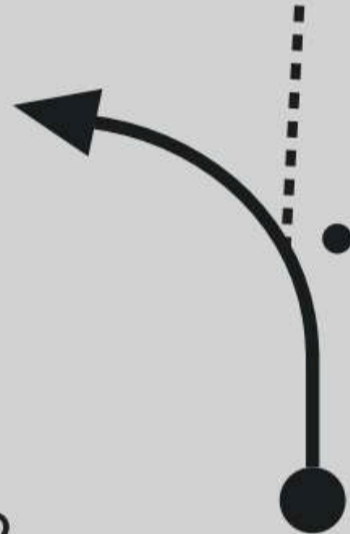

40°47'09.3"N 23°13'59.0"E



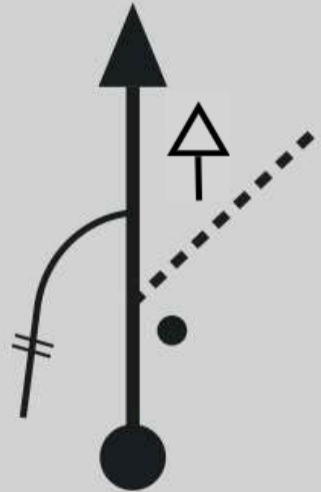

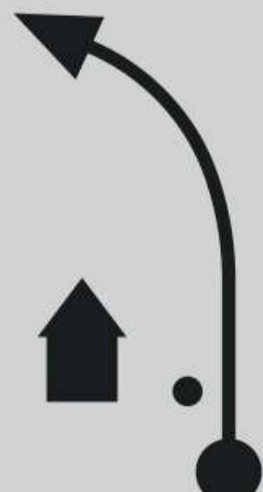

40°47'11"N 23°13'58"E



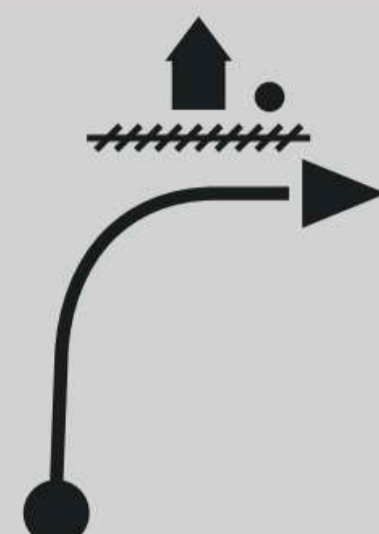
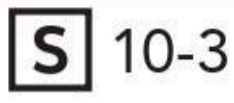
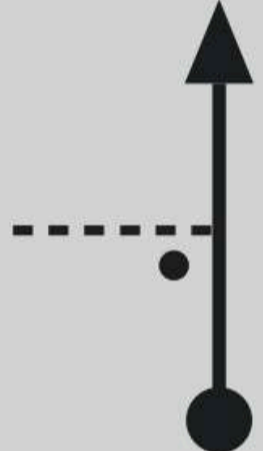
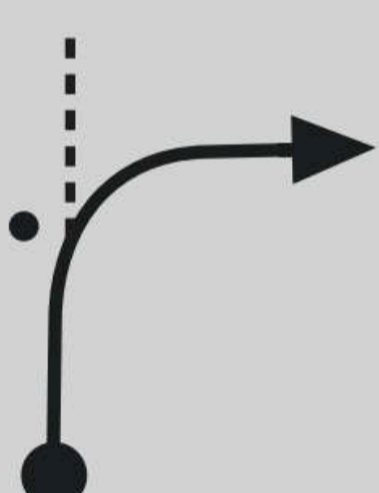
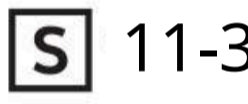
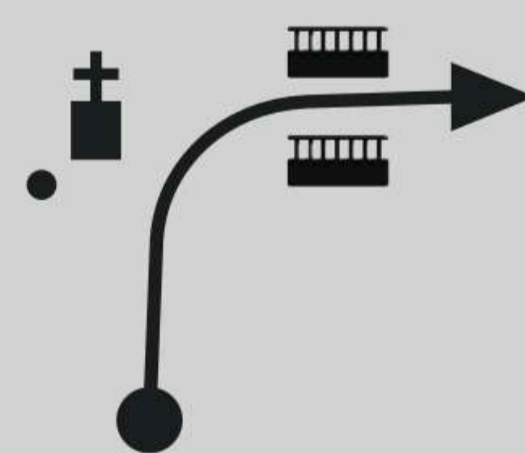

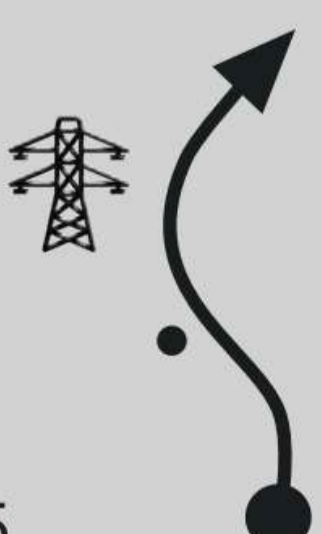





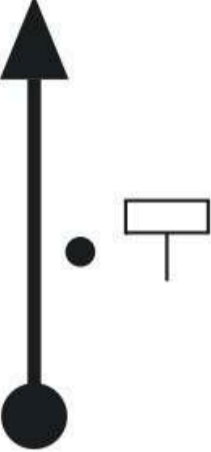

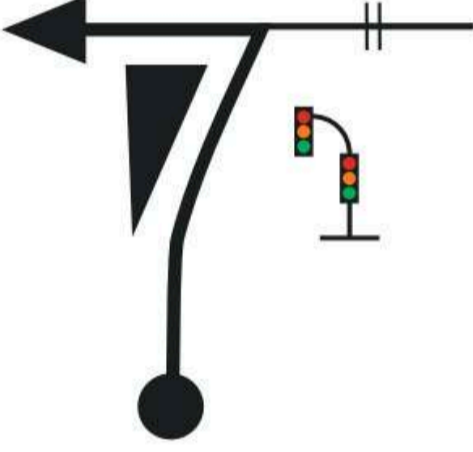

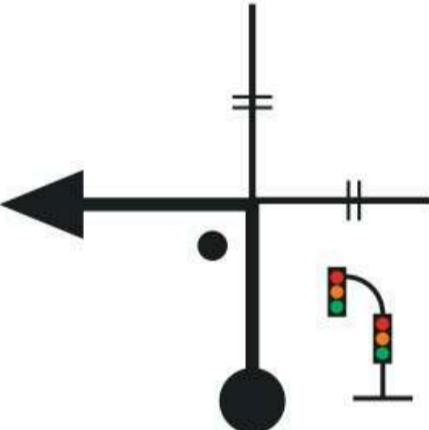

Σ.Ε.Χ. 3 ΠΕΝΤΕ ΒΡΥΣΣΕΣ ΙΙΙ		ΑΠΟΣΤΑΣΗ 32,22 χλμ.		ΣΚΕΛΟΣ 1	ΣΕΛ 18
Σ.Ε.Χ. 3Α ΤΕΡΜΑΤΙΣΜΟΣ ΛΟΥΤΡΑ ΛΑΓΚΑΔΑ				ΤΜΗΜΑ 3	
ΕΙΔΙΚΗ ΔΙΑΔΡΟΜΗ 3 - ΠΕΝΤΕ ΒΡΥΣΣΕΣ		13,40 χλμ.		Μ.Ω.Τ. 48,33 χλμ.	ΙΔΑΝΙΚΟΣ ΧΡΟΝΟΣ 40'
ΟΛΙΚΑ ΧΛΜ	ΜΕΡΙΚΑ ΧΛΜ	ΚΑΤΕΥΘΥΝΣΗ		ΠΛΗΡΟΦΟΡΙΕΣ	ΥΠΟΛ ΧΛΜ
0,00	0,00	1		       ΑΦΕΤΗΡΙΑ Ε. Δ. 3 ΠΕΝΤΕ ΒΡΥΣΣΕΣ ΙΙΙ 	32,22
0,41	0,41	2			31,83
1,66	1,27	3		 E2-3	30,56
2,41	0,75	4			29,81
3,14	0,73	5		 E4-3	29,08

Σ.Ε.Χ. 3 ΠΕΝΤΕ ΒΡΥΣΣΕΣ ΙΙΙ		ΑΠΟΣΤΑΣΗ 32,22 χλμ.		ΣΚΕΛΟΣ 1	ΣΕΛ 19
Σ.Ε.Χ. 3Α ΤΕΡΜΑΤΙΣΜΟΣ ΛΟΥΤΡΑ ΛΑΓΚΑΔΑ				ΤΜΗΜΑ 3	
ΕΙΔΙΚΗ ΔΙΑΔΡΟΜΗ 3 - ΠΕΝΤΕ ΒΡΥΣΣΕΣ ΙΙΙ		13,40 χλμ.		Μ.Ω.Τ. 48,33 χλμ.	ΙΔΑΝΙΚΟΣ ΧΡΟΝΟΣ 40'
ΟΛΙΚΑ ΧΛΜ	ΜΕΡΙΚΑ ΧΛΜ	ΚΑΤΕΥΘΥΝΣΗ	ΠΛΗΡΟΦΟΡΙΕΣ	ΥΠΟΛ ΧΛΜ	
3,56	0,42	6	 Κ.Π.Ε. ΒΕΡΤΙΣΚΟΥ E5-3	28,66	
3,91	0,35	7	!! I. Μ. ΑΓΙΟΥ ΘΕΟΔΩΡΟΥ ΓΑΒΡΑ S 6-3	28,31	
4,80	0,89	8	 ΣΙΚΕΪΝ E7-3	27,42	
4,88	0,08	9	 S 8-3	27,34	
6,52	1,64	10	 ΟΣΣΑ 5 ΒΕΡΤΙΣΚΟΣ 11 E9-3	25,7	

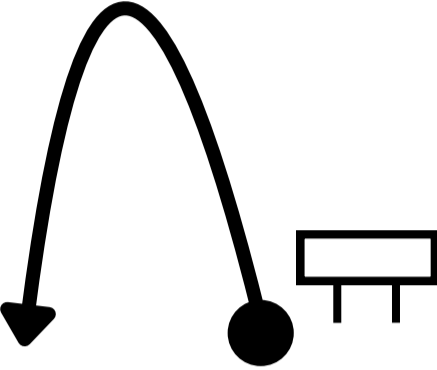
Σ.Ε.Χ. 3 ΠΕΝΤΕ ΒΡΥΣΕΣ ΙΙΙ		ΑΠΟΣΤΑΣΗ 32,22 χλμ.		ΣΚΕΛΟΣ 1	ΣΕΛ 20
Σ.Ε.Χ. 3Α ΤΕΡΜΑΤΙΣΜΟΣ ΛΟΥΤΡΑ ΛΑΓΚΑΔΑ				ΤΜΗΜΑ 3	
ΕΙΔΙΚΗ ΔΙΑΔΡΟΜΗ 3 - ΠΕΝΤΕ ΒΡΥΣΕΣ ΙΙΙ		13,40 χλμ.		Μ.Ω.Τ. 48,33 χλμ.	ΙΔΑΝΙΚΟΣ ΧΡΟΝΟΣ 40'
ΟΛΙΚΑ ΧΛΜ	ΜΕΡΙΚΑ ΧΛΜ	ΚΑΤΕΥΘΥΝΣΗ		ΠΛΗΡΟΦΟΡΙΕΣ	ΥΠΟΛ ΧΛΜ
8,12	1,52	11			24,10
8,62	0,50	12			23,60
9,70	1,08	13			22,52
10,39	0,69	14		 E12-3	21,83
11,41	1,02	15		  ΠΥΛΩΝΕΣ Δ.Ε.Η.	20,81

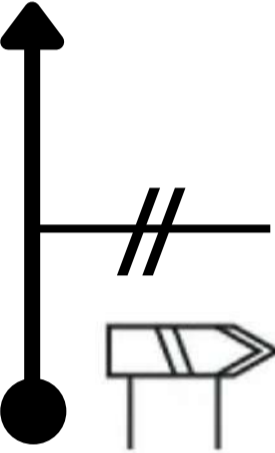
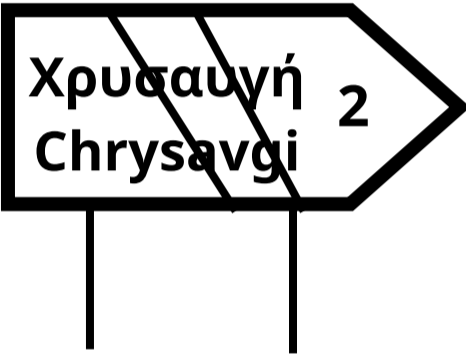
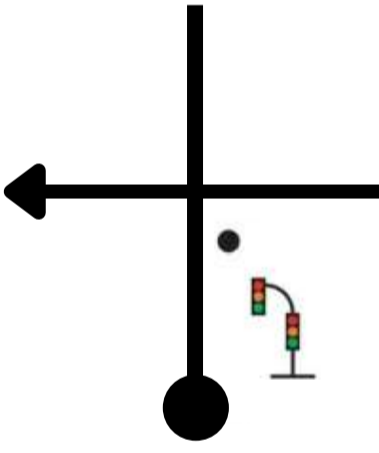
Σ.Ε.Χ. 3 ΠΕΝΤΕ ΒΡΥΣΣΕΣ III		ΑΠΟΣΤΑΣΗ 32,22 χλμ.	ΣΚΕΛΟΣ 1	ΣΕΛ 21
Σ.Ε.Χ. 3Α ΤΕΡΜΑΤΙΣΜΟΣ ΛΟΥΤΡΑ ΛΑΓΚΑΔΑ			ΤΜΗΜΑ 3	
ΕΙΔΙΚΗ ΔΙΑΔΡΟΜΗ 3 - ΠΕΝΤΕ ΒΡΥΣΣΕΣ III		13,40 χλμ.	Μ.Ω.Τ. 48,33 χλμ.	ΙΔΑΝΙΚΟΣ ΧΡΟΝΟΣ 40'
ΟΛΙΚΑ ΧΛΜ	ΜΕΡΙΚΑ ΧΛΜ	ΚΑΤΕΥΘΥΝΣΗ	ΠΛΗΡΟΦΟΡΙΕΣ	ΥΠΟΛ ΧΛΜ
13,40	1,99	16	 FLYING Ε.Δ. 3 ΠΕΝΤΕ ΒΡΥΣΣΕΣ	18,82
13,60	0,20	17	 STOP Ε.Δ. 3 ΠΕΝΤΕ ΒΡΥΣΣΕΣ	18,62
13,70	0,10	18		18,52
24,10	10,40	19		8,12
24,20	0,10	20		8,02

Σ.Ε.Χ. 3 ΠΕΝΤΕ ΒΡΥΣΕΣ ΙΙΙ		ΑΠΟΣΤΑΣΗ 32,22 χλμ.		ΣΚΕΛΟΣ 1	ΣΕΛ 22
Σ.Ε.Χ. 3Α ΤΕΡΜΑΤΙΣΜΟΣ ΛΟΥΤΡΑ ΛΑΓΚΑΔΑ				ΤΜΗΜΑ 3	
ΕΙΔΙΚΗ ΔΙΑΔΡΟΜΗ 3 - ΠΕΝΤΕ ΒΡΥΣΕΣ ΙΙΙ		13,40 χλμ.	Μ.Ω.Τ. 48,33 χλμ.	ΙΔΑΝΙΚΟΣ ΧΡΟΝΟΣ	40'
ΟΛΙΚΑ ΧΛΜ	ΜΕΡΙΚΑ ΧΛΜ	ΚΑΤΕΥΘΥΝΣΗ	ΠΛΗΡΟΦΟΡΙΕΣ	ΥΠΟΛ ΧΛΜ	
29,16	4,96	21 	 ΚΑΛΩΣ ΗΛΘΑΤΕ ΣΤΟΝ ΛΑΓΚΑΔΑ	3,06	
30,17	1,01	22 		2,05	
30,30	0,13	23 		1,92	
32,22	1,92	24 	 ΤΕΡΜΑΤΙΣΜΟΣ ΕΙΣΟΔΟΣ ΚΤΙΡΙΟΥ ΛΟΥΤΡΩΝ ΕΠΙΤΡΕΠΕΤΑΙ Η ΠΡΟΑΦΙΞΗ 	0,00	

ΣΕΧ 1 / 2 / 3		ΑΠΟΣΤΑΣΗ 8,25 χλμ		ΣΕΛ 1
ΣΕΧ 1Α / 2Α / 3Α REGROUPING		Μ.Ω.Τ. 41,35 ΧΛΜ		ΙΔΑΝΙΚΟΣ ΧΡΟΝΟΣ 12'
ΟΛΙΚΑ ΧΛΜ	ΜΕΡΙΚΑ ΧΛΜ	ΚΑΤΕΥΘΥΝΣΗ	ΠΛΗΡΟΦΟΡΙΕΣ	ΥΠΟΛ ΧΛΜ
0,00	0,00	1 	 ΣΕΧ 1, 2, 3	8,25
2,93	2,93	2 	 Χρυσανγή 2 Chrysanvi	5,32
6,33	3,4	3 		1,92
8,25	1,92	4 	 ΣΕΧ 1Α, 2Α, 3Α ΕΙΣΟΔΟΣ ΚΤΙΡΙΟΥ ΛΟΥΤΡΩΝ	0,00